

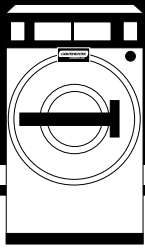

**GIRBAU, INC.**

2500 State Road 44 • Oshkosh, WI 54904  
 (920) 231-8222 • FAX (920) 231-4666  
 www.cont-girbau.com



# L1050

## WASHER-EXTRACTOR

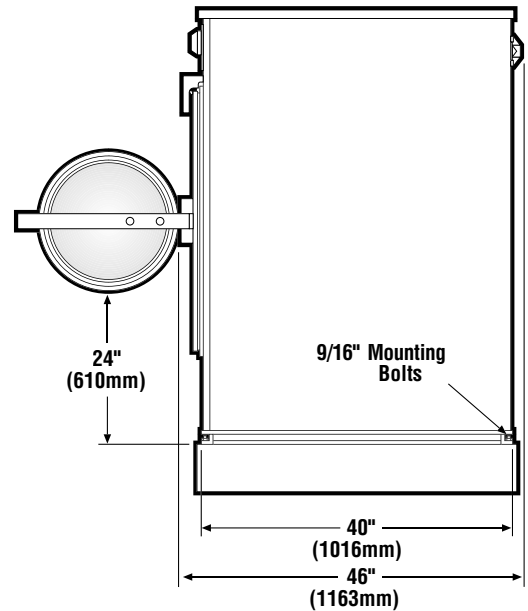
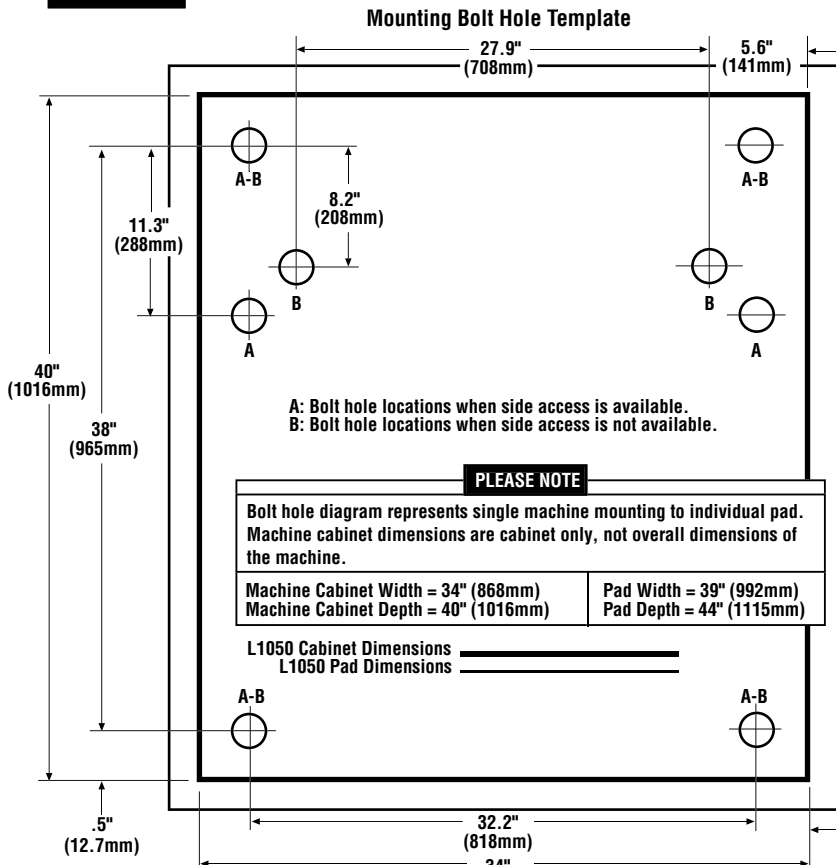

**Machine Front**

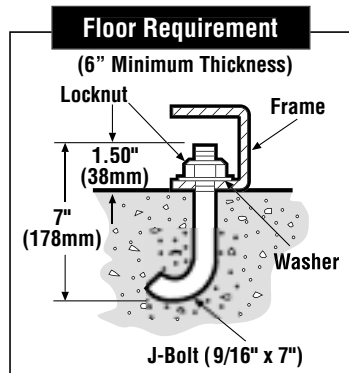
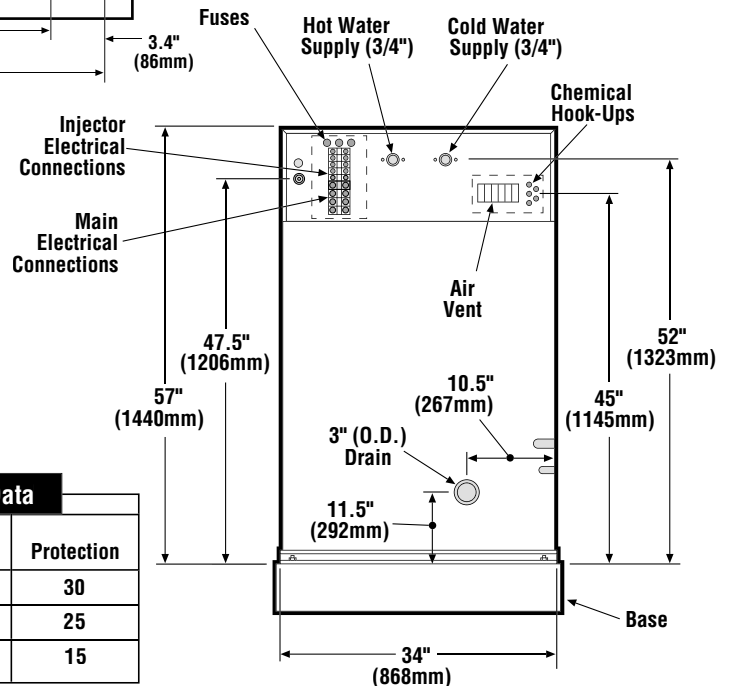

Electrical Data		
Voltage	Wire Config.	Protection
220-240/60/1	2W+G	30
208-240/60/3	3W+G	25
440-480/60/3	3W+G	15

Elevation Base Recommendation: 6" (152mm) Steel or Concrete

\*Specifications subject to change without notice.

## L1050 Product Technical Specifications

Capacity	50 lbs.	(21 kg.)
Cylinder Diameter	27.5 in.	(700 mm.)
Cylinder Depth	21.5 in.	(545 mm.)
Cylinder Volume	7.4 cu. ft.	(210 dm <sup>3</sup> )
Crated Weight	1,036 lbs.	(470 kg.)
Net Weight	889 lbs.	(403 kg.)
Height	57 in.	(1440 mm.)
Overall Depth (w/o handle)	46 in.	(1163 mm.)
Width	34 in.	(868 mm.)
Floor to Door (h)	24 in. plus base	(610 mm. plus base)
Washing Speed	45 rpm	
Spin Speed	515/450 rpm <b>SR-SM-PM/CR-CM</b>	
G Force	103/79 <b>SR-SM-PM/CR-CM</b>	
Drain	3 in.	(76 mm.)
Water	.75 in.	(19 mm.)
Steam	.5 in.	(12.7 mm.)
Motor Horsepower 3Ph	.57/2.7 HP <b>SR-SM-PM</b>	
Motor Horsepower 1Ph	.40/2.0 HP <b>CR-CM</b>	
Electric Heating (optional)	18 Kw	
Shipping Dimensions (W x H x D)	41 x 48 x 61 in.	(1040 x 1220 x 1550 mm.)
Minimum Clearance		
Rear	16 in.	(400 mm.)
Sides L&R	.5 in.	(13 mm.)
Front	39 in.	(1000 mm.)

## Chemical Hook-Up Information

TERMINAL CONNECTIONS ALL MODELS		CHEMICAL INJECTION (Dosing)	
		PM-CM-SM MODEL TERMINAL CONNECTIONS	S/R-C/R MODEL TERMINAL CONNECTIONS
Supply #	Conn. #		<b>SR</b> <b>CR</b>
5	X5-6	47	
4	X5-5	46	28      23
3	X5-4	45	27      22
2	X5-3	44	26      21
1	X5-2	43	25      20
Common	X5-1	207	207

