

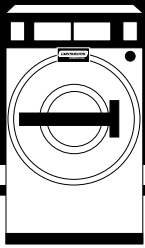

GIRBAU, INC.

2500 State Road 44 • Oshkosh, WI 54904
 (920) 231-8222 • FAX (920) 231-4666
 www.cont-girbau.com



L1040SR

WASHER-EXTRACTOR

Mounting Bolt Hole Template

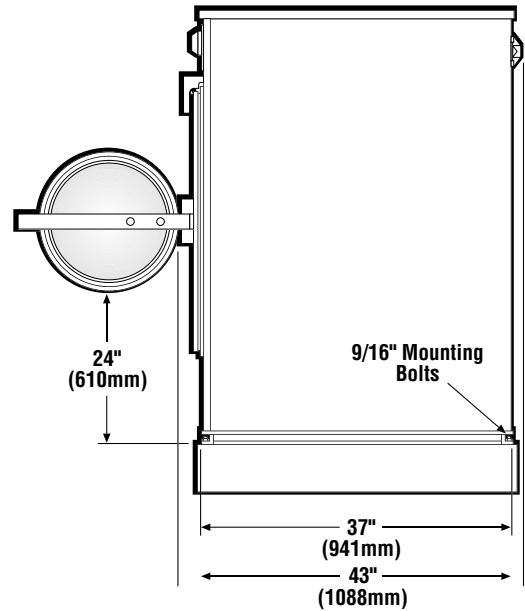
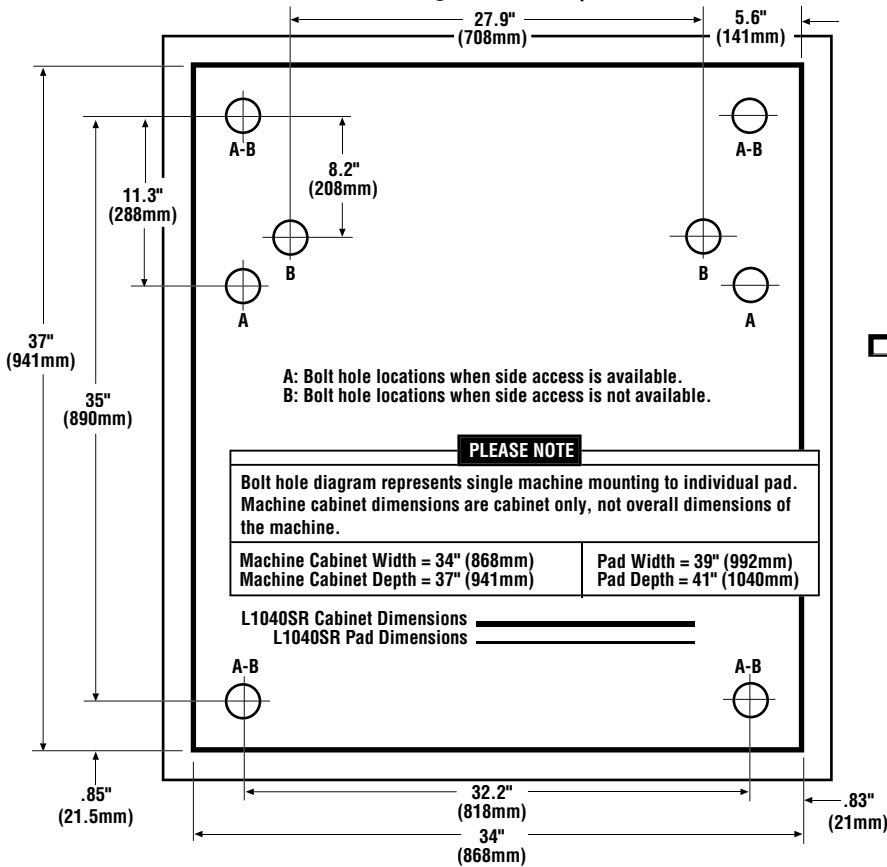

Machine Front

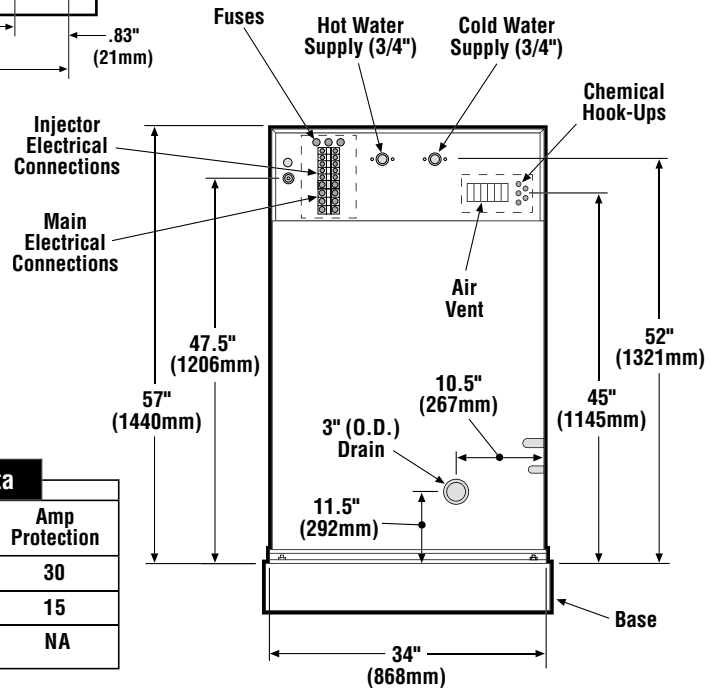

Floor Requirement

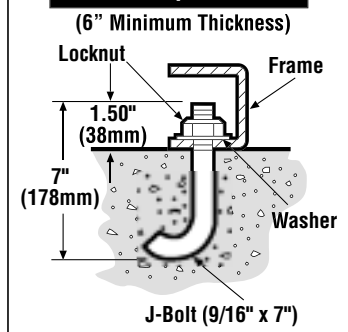

Electrical Data

Voltage	Wire Config.	Amp Protection
208-240/60/1	2W+G	30
208-240/60/3	3W+G	15
440/60/3	3W+G	NA

Elevation Base Recommendation: 6" (152mm) Steel or Concrete

*Specifications subject to change without notice.

L1040SR Product Technical Specifications

Capacity		40 lbs.	(18 kg.)
Cylinder Diameter		27.5 in.	(699 mm.)
Cylinder Depth		18.5 in.	(470 mm.)
Cylinder Volume		6.35 cu. ft.	(180 dm ³)
Crated Weight		992 lbs.	(450 kg.)
Net Weight		838 lbs.	(380 kg.)
Height		57 in.	(1440 mm.)
Overall Depth (w/o handle)		43 in.	(1088 mm.)
Width		34 in.	(868 mm.)
Floor to Door (h)		24 in. plus base	(610 mm. plus base)
Washing Speed	220-240/60/01	45 rpm	
	208-240/60/3	45 rpm	
Spin Speed	220-240/60/01	450 rpm	
	208-240/60/3	515 rpm	
G Force	220-240/60/01	79	
	208-240/60/3	103	
Drain	220-240/60/01	3 in.	(76 mm.)
	208-240/60/3	3 in.	(76 mm.)
Water	220-240/60/01	.75 in.	(19 mm.)
	208-240/60/3	.75 in.	(19 mm.)
Motor Horsepower	220-240/60/01	.45/2 HP	
	208-240/60/3	.5/2.7 HP	
Shipping Dimensions (W x D x H)		41 x 45 x 61 in.	(1040 x 1145 x 1550 mm.)
Minimum Clearance			
Rear		16 in.	(400 mm.)
Sides L&R		.5 in.	(13 mm.)
Front		39 in.	(1000 mm.)

Chemical Hook-Up Information

TERMINAL CONNECTIONS ALL MODELS		CHEMICAL INJECTION (Dosing)	
		PM-CM-SM MODEL TERMINAL CONNECTIONS	S/R-C/R MODEL TERMINAL CONNECTIONS
Supply #	Conn. #		SR CR
5	X5-6	47	
4	X5-5	46	28 23
3	X5-4	45	27 22
2	X5-3	44	26 21
1	X5-2	43	25 20
Common	X5-1	207	207

