

Architectural/Mechanical Product Specifications

CONTINENTAL[®]

GIRBAU, INC.

2500 State Road 44 • Oshkosh, WI 54904
(920) 231-8222 • FAX (920) 231-4666
www.cont-girbau.com

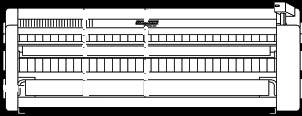

**F20058, F20075,
F20100, F20125**

**COMMERCIAL
FLATWORK IRONER**

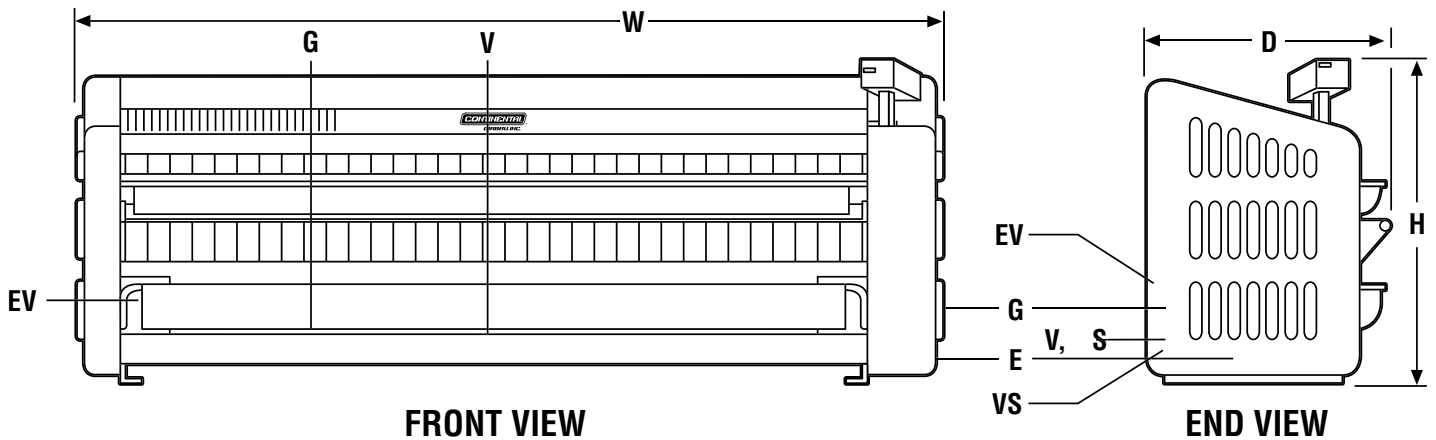

*Specifications subject to change without notice.

F20058, F20075, F20100, F20125 Product Technical Specifications

	Gas/Electric F20058W F20058F	Gas/Electric F20075W F20075F	Gas/Electric F20100W F20100F	Gas/Electric F20125W F20125F	Steam F20075W F20075F	Steam F20125W F20125F
Cylinder Diameter	20 in. (510 mm.)	20 in. (510 mm.)	20 in. (510 mm.)	20 in. (510 mm.)	20 in. (510 mm.)	20 in. (510 mm.)
Useful Cylinder Length	58.25 in. (1480 mm.)	75 in. (1900 mm.)	99.5 in. (2530 mm.)	124.5 in. (3165 mm.)	75 in. (1900 mm.)	124.5 in. (3165 mm.)
Evaporation	50 lbs./h. (23 l./h.)	66 lbs./h. (30 l./h.)	88 lbs./h. (40 l./h.)	110 lbs./h. (50 l./h.)	92 lbs./h. (42 l./h.)	154 lbs./h. (70 l./h.)
Speed	3-21 ft./min. (1-6.5 m./min.)	3-21 ft./min. (1-6.5 m./min.)	3-21 ft./min. (1-6.5 m./min.)	3-21 ft./min. (1-6.5 m./min.)	3-21 ft./min. (1-6.5 m./min.)	3-21 ft./min. (1-6.5 m./min.)
SHIPPING WEIGHT:						
W	2,447 lbs. (1110 kg.)	2,976 lbs. (1350 kg.)	3,571 lbs. (1620 kg.)	4,001 lbs. (1815 kg.)	3,538 lbs. (1605 kg.)	5,269 lbs. (2390 kg.)
F	2,646 lbs. (1200 kg.)	3,219 lbs. (1460 kg.)	3,902 lbs. (1770 kg.)	4,409 lbs. (2000 kg.)	3,792 lbs. (1720 lbs.)	5,666 lbs. (2570 kg.)
NET WEIGHT:						
W	1,962 lbs. (890 kg.)	2,425 lbs. (1100 kg.)	2,921 lbs. (1325 kg.)	3,263 lbs. (1480 kg.)	2,987 lbs. (1355 kg.)	4,530 lbs. (2055 kg.)
F	2,138 lbs. (970 kg.)	2,634 lbs. (1195 kg.)	3,197 lbs. (1450 kg.)	3,616 lbs. (1640 kg.)	3,197 lbs. (1450 kg.)	4,883 lbs. (2215 kg.)
DIMENSIONS:						
Height (H)	55.9 in. (1420 mm.)	55.9 in. (1420 mm.)	55.9 in. (1420 mm.)	55.9 in. (1420 mm.)	55.9 in. (1420 mm.)	55.9 in. (1420 mm.)
Width (W)	85.4 in. (2170 mm.)	102.2 in. (2595 mm.)	127 in. (3225 mm.)	152 in. (3860 mm.)	104.9 in. (2665 mm.)	154.7 in. (3930 mm.)
Depth (D)	45.8 in. (1164 mm.)	45.8 in. (1164 mm.)	45.8 in. (1164 mm.)	45.8 in. (1164 mm.)	45.8 in. (1164 mm.)	45.8 in. (1164 mm.)
MINIMUM CLEARANCE:						
Rear	20 in. (50 cm.)	20 in. (50 cm.)	20 in. (50 cm.)	20 in. (50 cm.)	20 in. (50 cm.)	20 in. (50 cm.)
Sides (L&R)	20 in. (50 cm.)	20 in. (50 cm.)	20 in. (50 cm.)	20 in. (50 cm.)	20 in. (50 cm.)	20 in. (50 cm.)
Front	48 in. (122 cm.)	48 in. (122 cm.)	48 in. (122 cm.)	48 in. (122 cm.)	48 in. (122 cm.)	48 in. (122 cm.)
STEAM & GAS:						
Exhaust Dia. EV	5 in. (130 mm.)	5 in. (130 mm.)	5 in. (130 mm.)	5 in. (130 mm.)	5 in. (130 mm.)	5 in. (130 mm.)
Exhaust Air Flow	29,805 CFH (844 m ³ /h.)	29,805 CFH (844 m ³ /h.)	29,805 CFH (844 m ³ /h.)	29,805 CFH (844 m ³ /h.)	29,805 CFH (844 m ³ /h.)	29,805 CFH (844 m ³ /h.)
Gas Inlet Diameter	.75 in. (19 mm.)	.75 in. (19 mm.)	.75 in. (19 mm.)	.75 in. (19 mm.)	-	-
Gas Supply NAT/	6.5 (±1.5)	6.5 (±1.5)	6.5 (±1.5)	6.5 (±1.5)	6.5 (±1.5)	6.5 (±1.5)
Prop inches WC	11 (±.3)	11 (±.3)	11 (±.3)	11 (±.3)	11 (±.3)	11 (±.3)
Motor Horsepower	1.5	1.5	1.5	1.5	1.5	1.5
CV	1.5	1.5	1.5	1.5	1.5	1.5
Electric Heating (Opt.)	28 Kw	35.5 Kw	47 Kw	60 Kw	-	-
CIRCUIT PROTECTION:						
Electrical: 208-240/60/3	100 Amps	125 Amps	160 Amps	200 Amps	-	-
Gas: 208-240/60/3	16 Amps	16 Amps	16 Amps	16 Amps	16 Amps	16 Amps
GAS POWER G:						
BTUH	111,000	143,000	186,500	238,000	-	-
kcal./h.	28 000	35 500	47 000	60 000	-	-
STEAM POWER:						
BTUH	-	-	-	-	166,500	277,750
kcal./h.	-	-	-	-	42 000	70 000
BHP	-	-	-	-	4.97	8.3
Steam Inlet Dia. V	-	-	-	-	1 in. (25.4 mm.)	1 in. (25.4 mm.)
Condensate Outlet	-	-	-	-	.75 in. (19 mm.)	.75 in. (19 mm.)
Dia. C						
Safety Valve	-	-	-	-	.50 in. (12.7 mm.)	.50 in. (12.7 mm.)
Discharge Dia. VS						

**International Voltages Available



2500 State Road 44 • Oshkosh, WI 54904 • (920) 231-8222 • FAX (920) 231-4666 • www.cont-girbau.com