

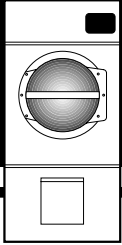

GIRBAU, INC.

2500 State Road 44 • Oshkosh, WI 54904
 (920) 231-8222 • FAX (920) 231-4666
 www.cont-girbau.com



CG30-40 DRYER

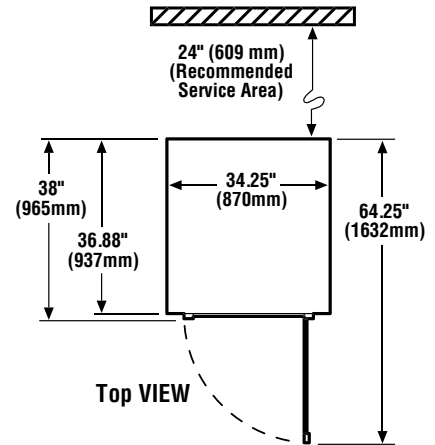
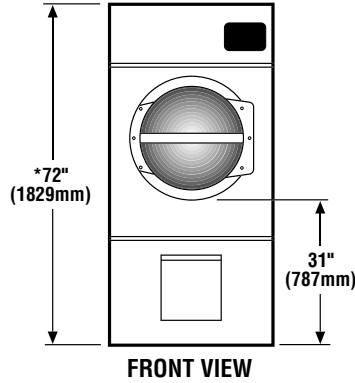
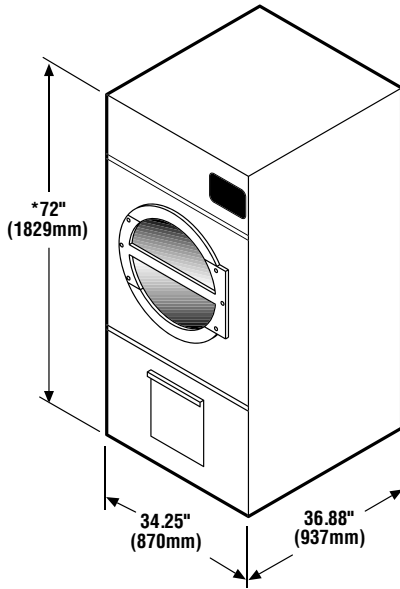

- * Operating height of steam dryer is 77" (1956mm).
- ** Size of piping to dryer varies with installation conditions. Contact factory for assistance.
- *** Duct work size varies with installation conditions. Exhaust static pressure should not exceed 0.3" (0.74 mb) water column
- **** Steam dryers must be provided with clean, dry, regulated 80 psi ± 10 psi (5.5 bar ± 0.69 bar) air supply.

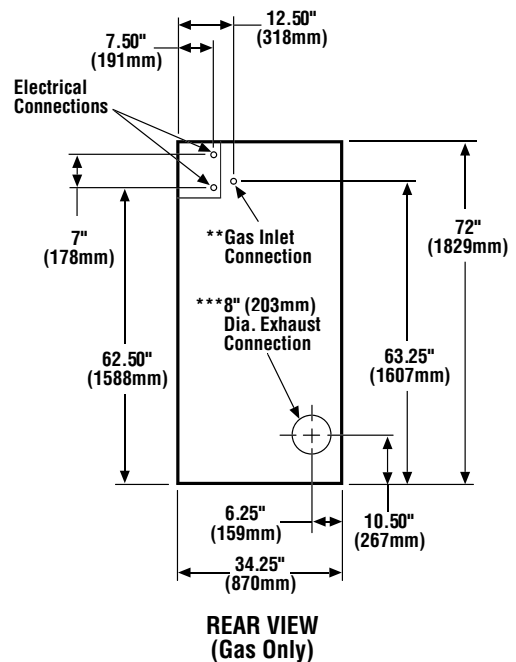
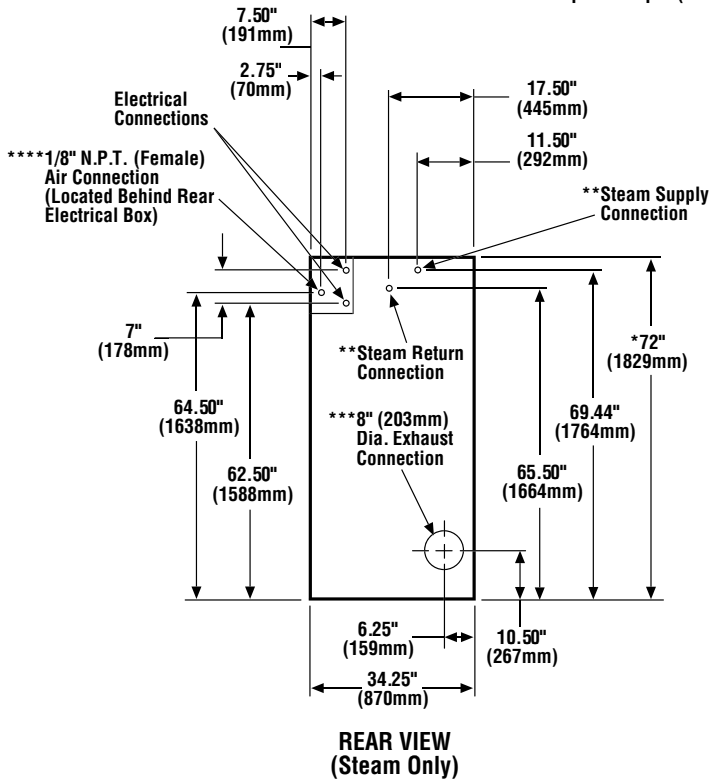

*Specifications subject to change without notice.

CG30-40 Product Technical Specifications

Drying capacity up to 40 lbs.

BASKET DIAMETER		32-3/4"		83.2 cm												
BASKET DEPTH		25-5/8"		65.1 cm												
BASKET MOTOR*		1/2 hp		0.373 kw												
DOOR OPENING (DIAMETER)		21-1/2"		54.6 cm												
BASKET VOLUME		12.5 cu.ft.		0.354 cu.m.												
EXHAUST CONNECTION (DIAMETER)**		8"		20.32 cm												
DRYERS PER 20'/40' CONTAINER				12/26												
DRYERS PER 45'/48' TRUCK				30/32												
GAS	VOLTAGE AVAILABLE		120-460v/1,3ø/3w,4w/50/60 Hz													
	AIRFLOW		460 cfm		13.03 cmm											
	APPROX. NET WEIGHT		534 lbs		242.2 kg											
	APPROX. SHIPPING WEIGHT		571 lbs		259 kg											
	HEAT INPUT		100,000 btu/hr		25,200 kcal/hr											
	INLET PIPE CONNECTION***		1/2" N.P.T. (Male)													
ELECTRIC	AIRFLOW		750 cfm		21.2 cmm											
	OVEN SIZE															
	KW		BTU/HR	60 HZ		50 HZ										
			15	51,200	12,900											
			20	68,250	17,200											
			24	81,900	20,640											
			30	102,400	25,800											
	APPLIED VOLTAGE/PHASE/APPROX. AMP DRAW ****															
	KW		208/1Ø		240/1Ø		208/3Ø		240/3Ø		380/3Ø		416/3Ø		460/3Ø	
			60 Hz	50 Hz	60 Hz	50 Hz	60 Hz	50 Hz	50/60 Hz	60 Hz	50 Hz	60 Hz	50 Hz	60 Hz	50 Hz	
15			-	-	-	-	45	-	39	-	25	-	-	-	-	
20			102	-	89	-	-	-	-	33	-	-	-	-	-	
24			-	-	-	-	70	-	58	-	-	-	36	32	-	
30	-	-	-	-	86	-	76	-	-	-	44	40	-			
STEAM	VOLTAGE AVAILABLE		120-460v/1,3ø/3w,4w/50/60 Hz													
	AIRFLOW		750 cfm		21.2 cmm											
	APPROX. NET WEIGHT		593 lbs		269 kg											
	APPROX. SHIPPING WEIGHT		631 lbs		286.2 kg											
	COMPRESSED AIR VOLUME		0.5 cfh		0.014 cmh											
	COMPRESSED AIR CONNECTION		1/8" N.P.T. (Female)													
	STEAM CONSUMPTION		BOILER HP NORMAL LOAD													
	104 lbs/hr	47.2 kg/hr	3													
OPERATING STEAM PRESSURE		SUPPLY CONNECTION***		RETURN CONNECTION***												
125 psi max	8.6 bar	1" N.P.T. (Female)		1" N.P.T. (Female)												

- * CG30-40 1ø dryers use a 1/2 hp motor. CG30-40 3ø non-reversing dryers use a 1/2 hp motor. All CG30-40 reversing dryers are supplied with two 3ø motors standard: a 1/2 hp blower motor and a 1/2 hp drive motor.
- ** Ductwork size varies with installation conditions. Exhaust static pressure should not exceed 0.3" (0.74 mb) water column.
- *** Size of piping to dryer varies with installation conditions. Contact factory for assistance.
- **** Contact factory for electrical information not listed. 3-Phase (3ø) figures shown are for 3-wire service.
- ***** Specify air-operated or electromechanical steam damper system when ordering. Air-operated steam damper must be provided with a clean, dry, regulated 80 psi ± 10 psi (5.5 bar ± 0.69 bar) air supply.

Specifications subject to change without notice.

GAS/STEAM ELECTRICAL SERVICE SPECIFICATIONS (PER DRYER)†

IMPORTANT: **208 VAC and 230/240 VAC ARE NOT THE SAME.** When ordering, specify *exact* voltage.

NOTE: A. Circuit breakers are thermal/magnetic (industrial) motor curve type ONLY. For others, calculate/verify correct breaker size according to appliance amp draw rating and type of breaker to be used.

B. Circuit breakers for 3Ø dryers **must be** 3-pole type.

SERVICE VOLTAGE	PHASE	WIRE SERVICE	APPROX. AMP DRAW		CIRCUIT BREAKER AMPERAGE
			60 Hz	50 Hz	
120	1ø	2	9.6	-	15
208	1ø	2	6.0	-	15
240	1ø	2	5.3	-	15
208	3ø	3/4	2.9	-	15
240	3ø	3	3.2	3.5	15
380/400	3ø	3/4	-	2.2	15
416	3ø	3/4	-	2.3	15
460/480	3ø	3/4	2.1	-	15

† Figures shown are for non-reversing models. Contact factory for information not listed

